

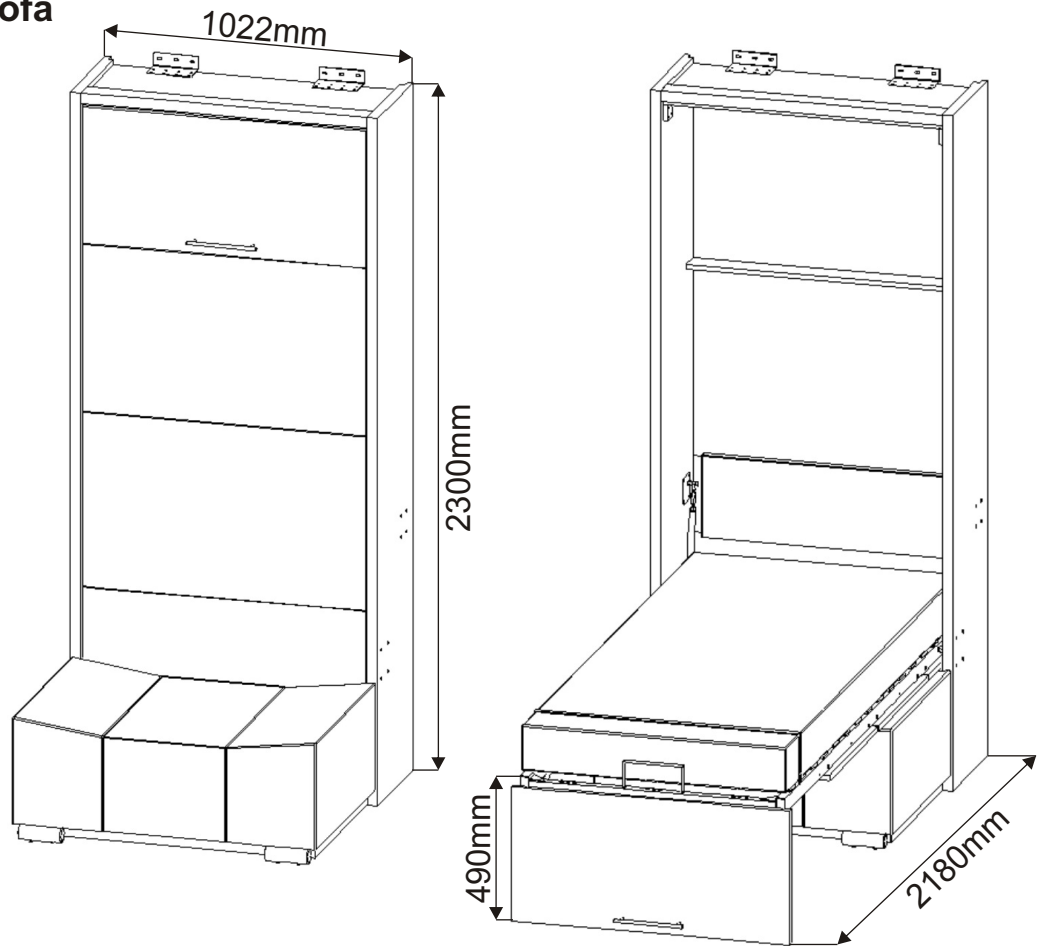

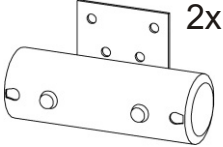

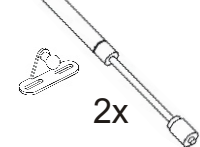

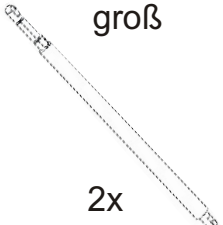

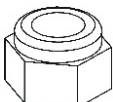

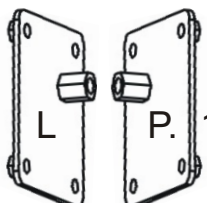
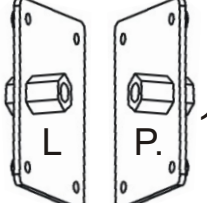

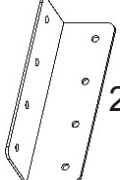
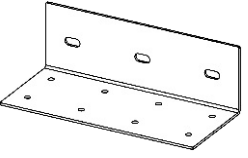
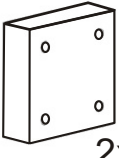
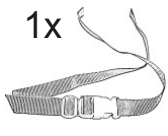
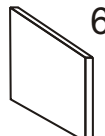

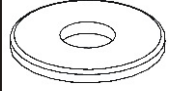

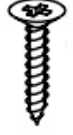
# VS 21058P 90 - Sofa

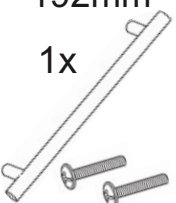

das Zylindrisches Metallbein 50mm  2x	der Gaskolben klein 80N  2x	der Gaskolben groß  2x	die Mutter M8  2x
---	--	--	---

der Verbindungsmechanismus Groß  16x 16x	das Absetzblech 80x90  1x L 1x P.	das Absetzblech 100x120  1x L 1x P.	der Nagel  90x	M 6x35 die Senkschraube  16x	das Verbindungsblech 100x30  2x
---	---	---	--	--	---

der Winkel 150x85x45  2x	der Türstopper  2x	der Gurt  1x	Vorbereitung zur korrekten Türmontage MDF 3mm  6x	die Schraubenabdeckung  30x	die Unterlage M13  4x	V4x35  8x	V4x50  8x
---	--	--	---	---	---	---	---

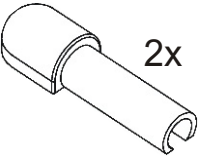
der Halter 192mm  1x	der Dübel Ø12  6x	M8x25  2x	M12x70  2x	V4x17  52x	V4x20  24x	V4x30  5x	V6x70  6x	V4x16  26x	der Kolbenabdeckung  2x
---	---	---	--	--	--	--	---	--	---

1.

Es ist wichtig, die Verbindungsmechanismen auf beiden Seiten gleichzeitig zu klopfen, um ein Brechen zu vermeiden.

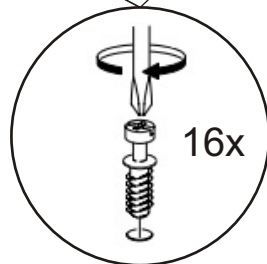
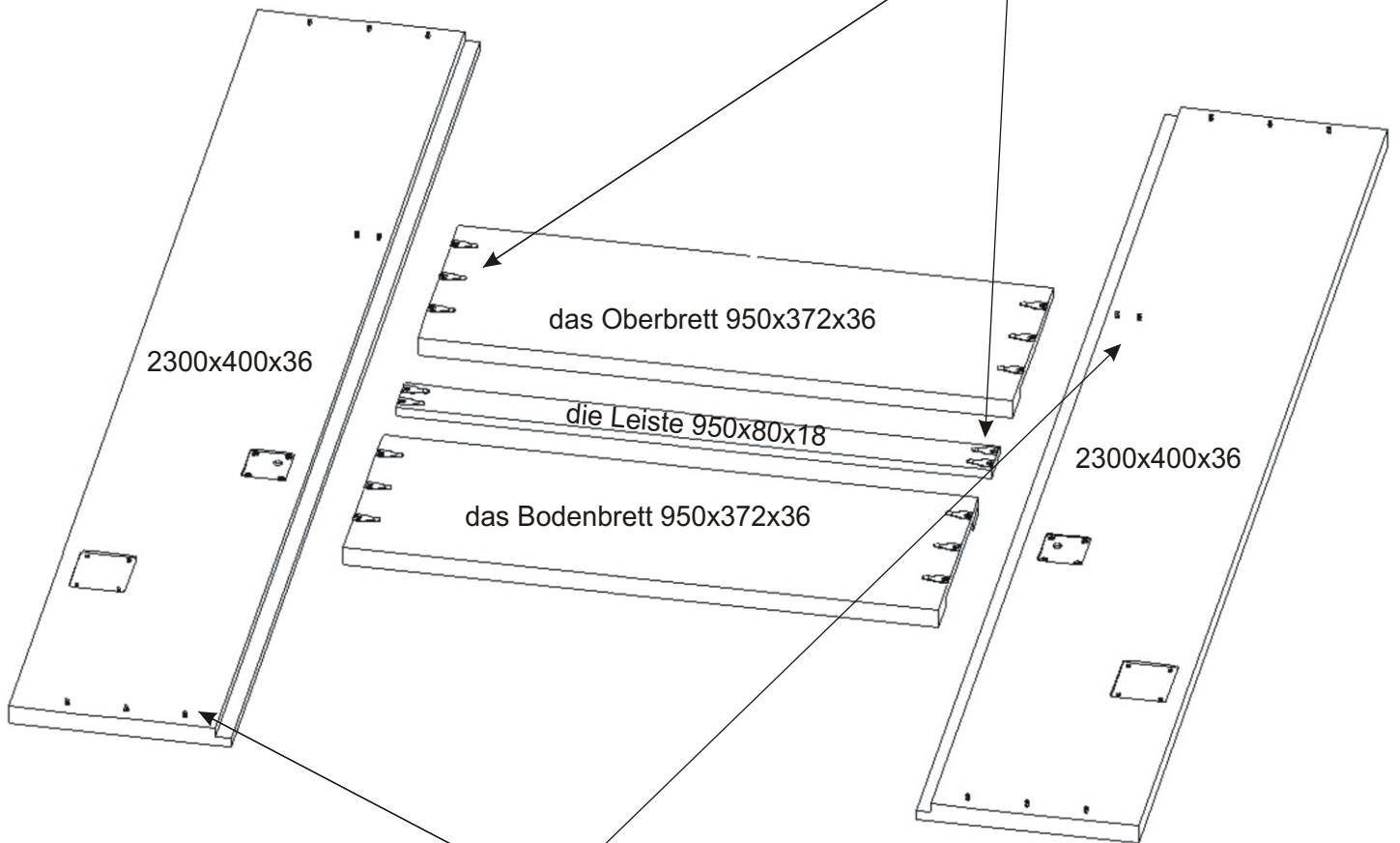
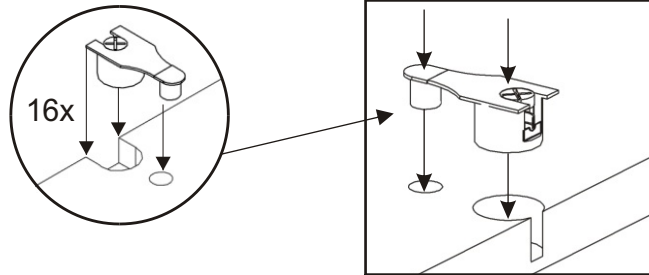

2.

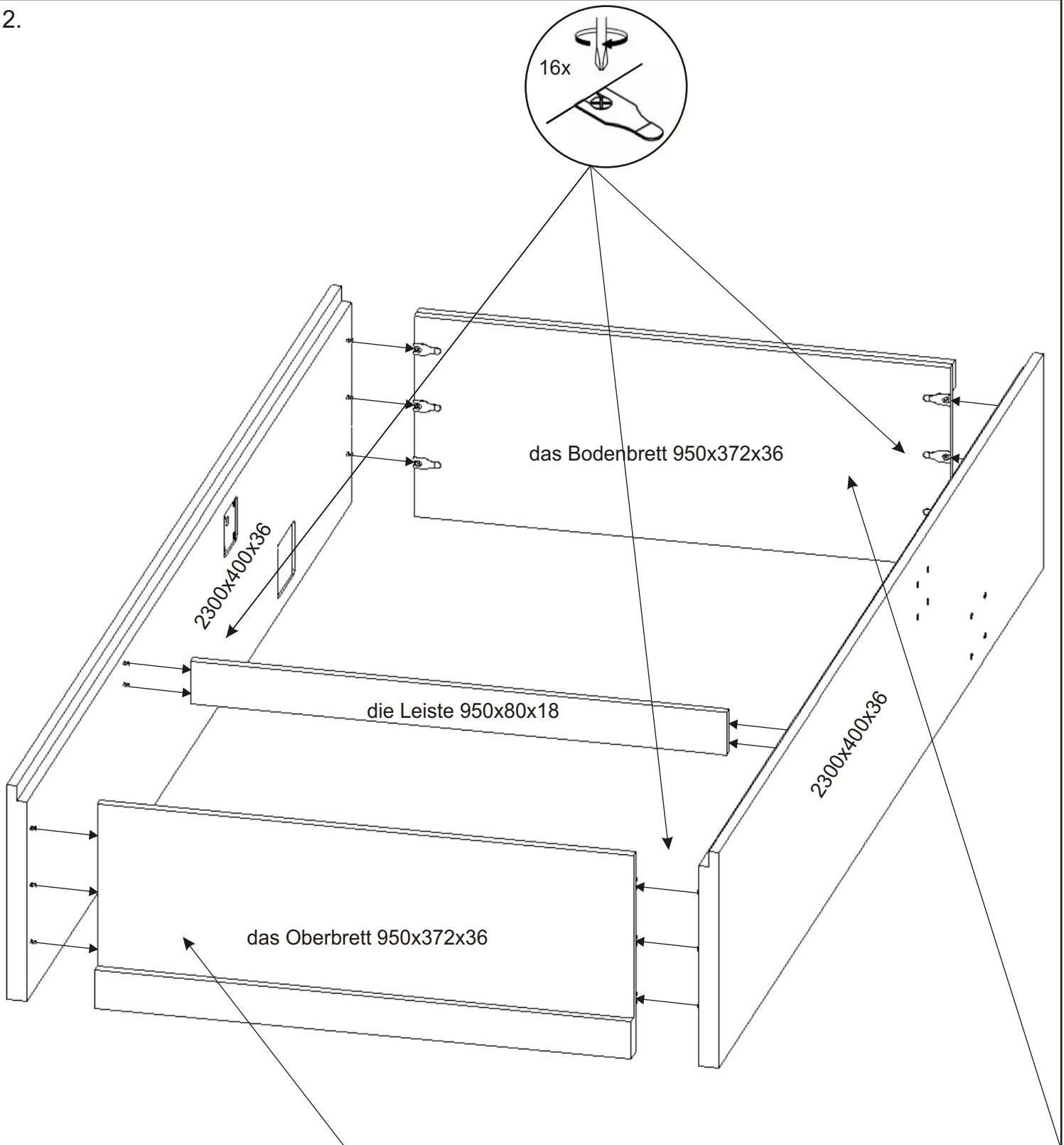

das Oberbrett

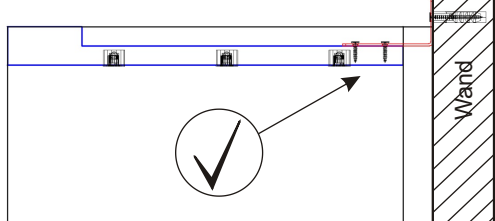

das Oberbrett

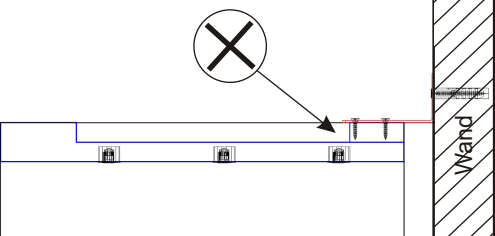

**Es ist wichtig, die obere Platte des Korpus und die untere Platte des Korpus nicht zu verwechseln! Andernfalls droht das Klappbett zu fallen und die Gefahr eines schweren Unfalls.**

das Bodenbrett

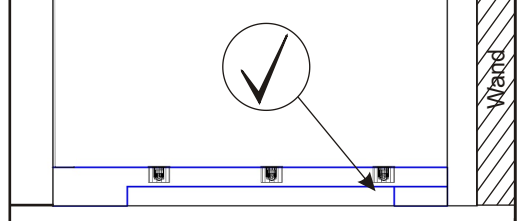

das Bodenbrett

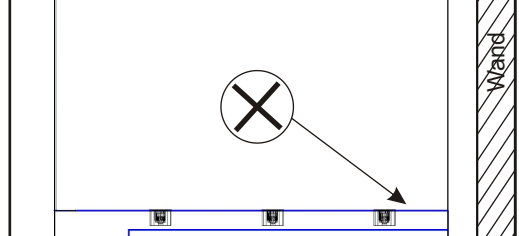

3.

der Nagel

90x



Befestigen Sie die Rückseite mit den Nägeln an dem Körper.

V 4x16

10x



MDF 983x665x3

das Bodenbrett 950x372x36

die Rückenbrettenbreite  
983x280

2300x400x36

V 4x50

8x



die Rückenbrettenbreite  
983x280

MDF 983x665x3

L1

MDF 983x665x3

L2

MDF 983x665x3

das Oberbrett 950x372x36

Messen und richten Sie die Diagonalen aus L1=L2, bevor Sie die Rückseite des Schrankes anbringen.

4.

Heben Sie den Körper des Bettes mit einem Kollegen an.

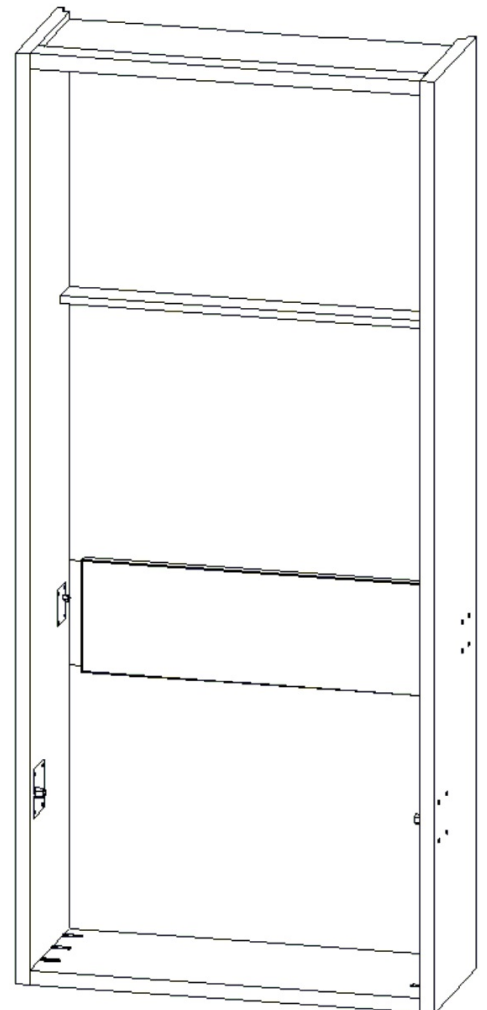
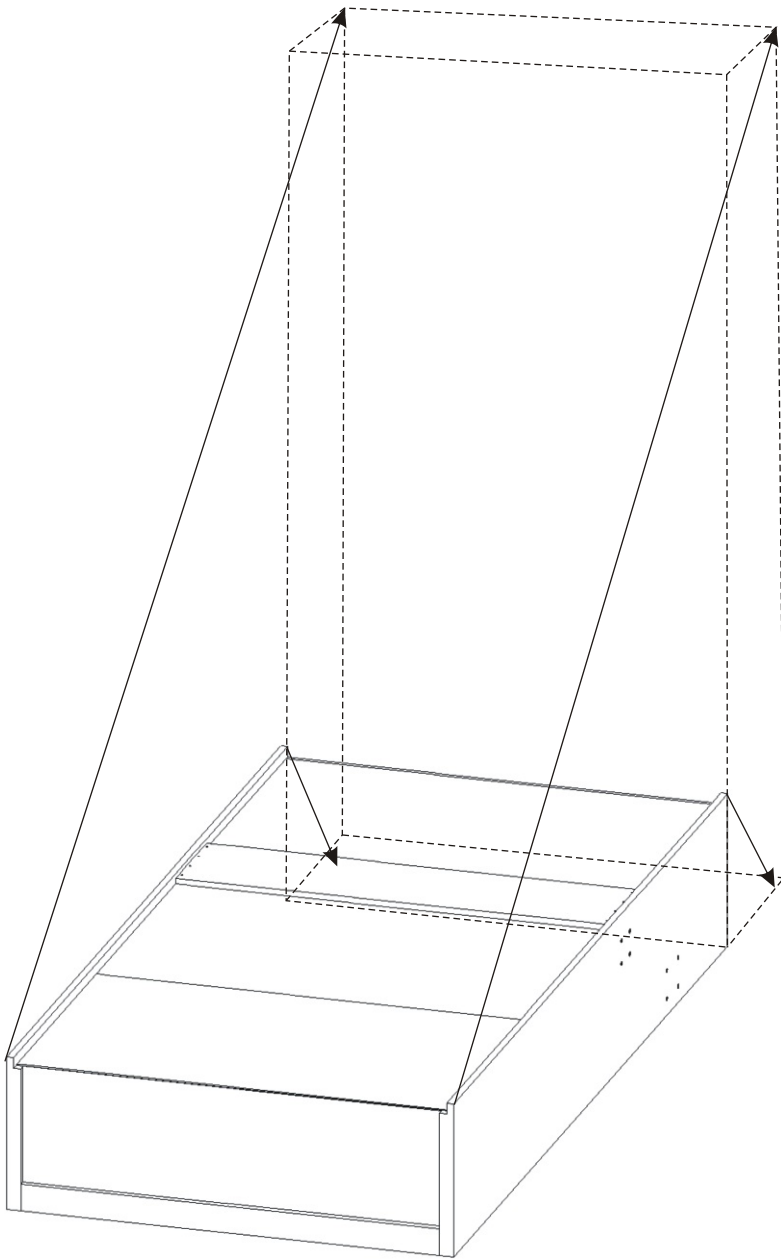

5.

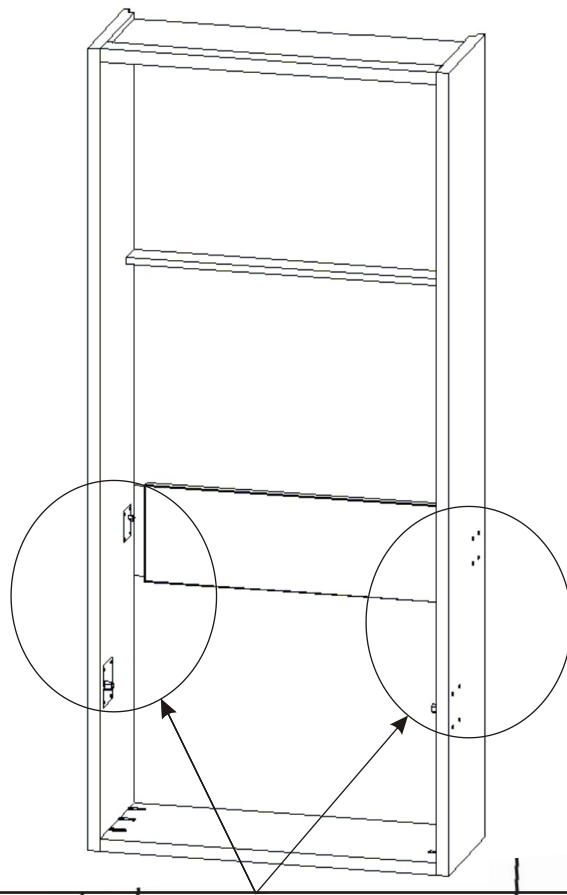

die  
Senkschraube  
M 6x35

16x

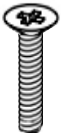

die Schrauben-  
abdeckung

16x



die Seite 2300x400x36

die Front

die furnierte Vorderkante

das Absetzblech

80x90

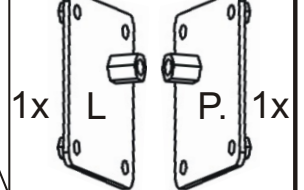

1x

1x

das Absetzblech

100x120

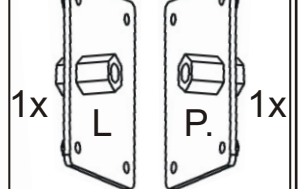

1x

1x

6.

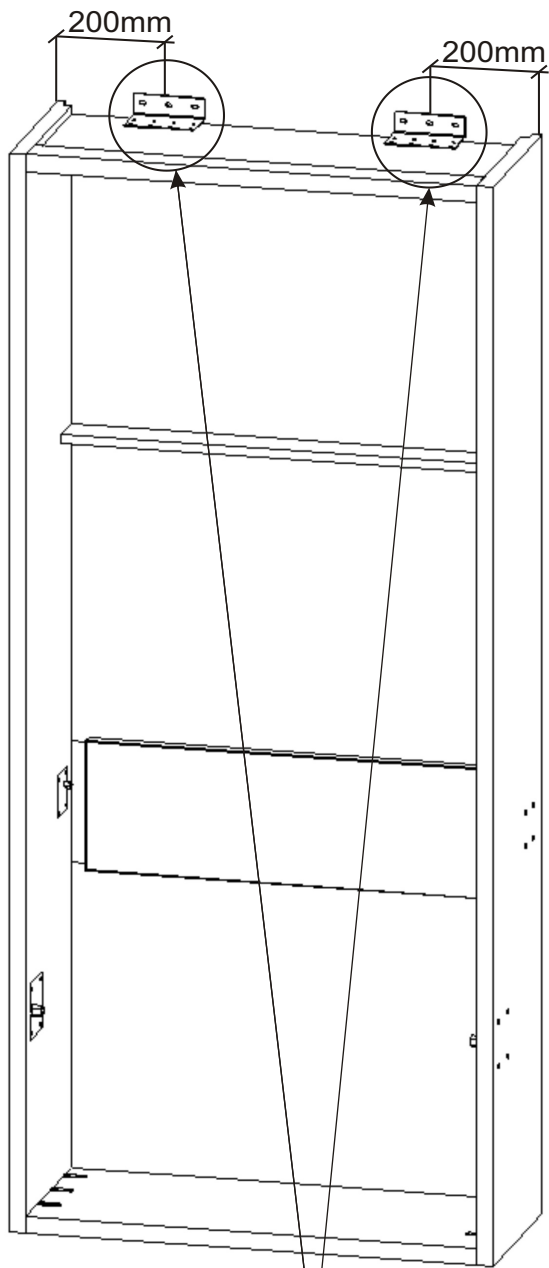

*Das Klappbett muss vor dem Anbringen des Metallrostes an der Wand befestigt werden!  
Andernfalls besteht Sturzgefahr beim Öffnen.*

*Die Anzahl und die Art der Dübeln muss durch die Art der Wand bestimmt werden.*

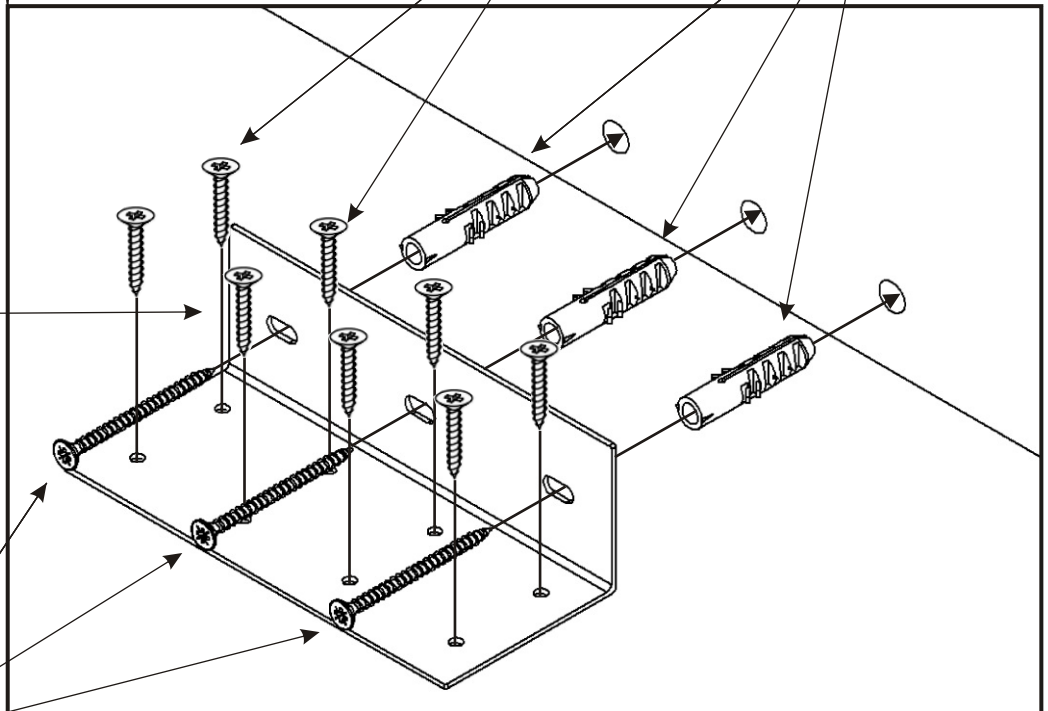
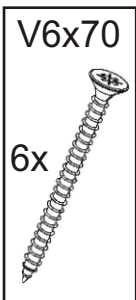
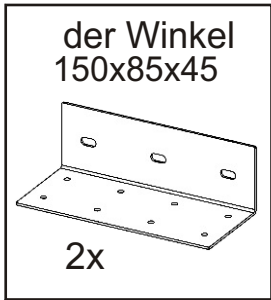
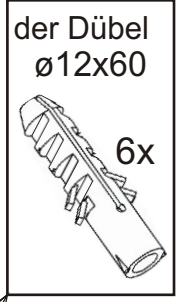
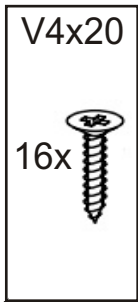

7.

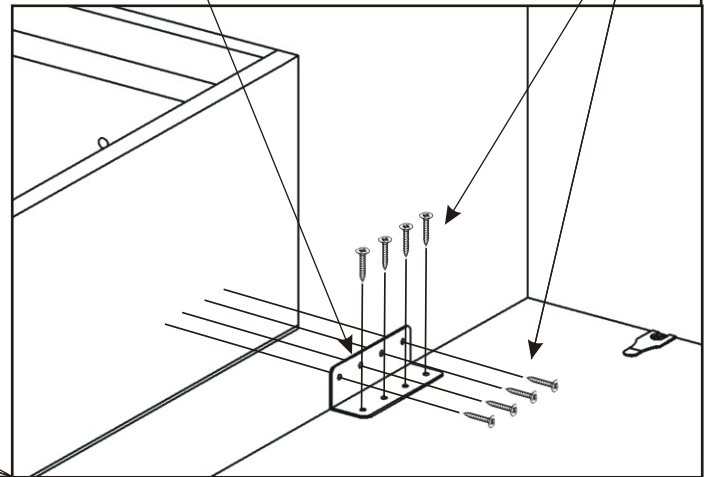
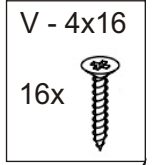
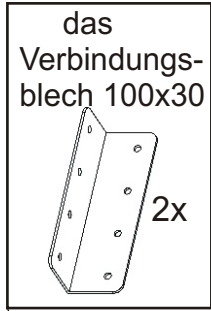
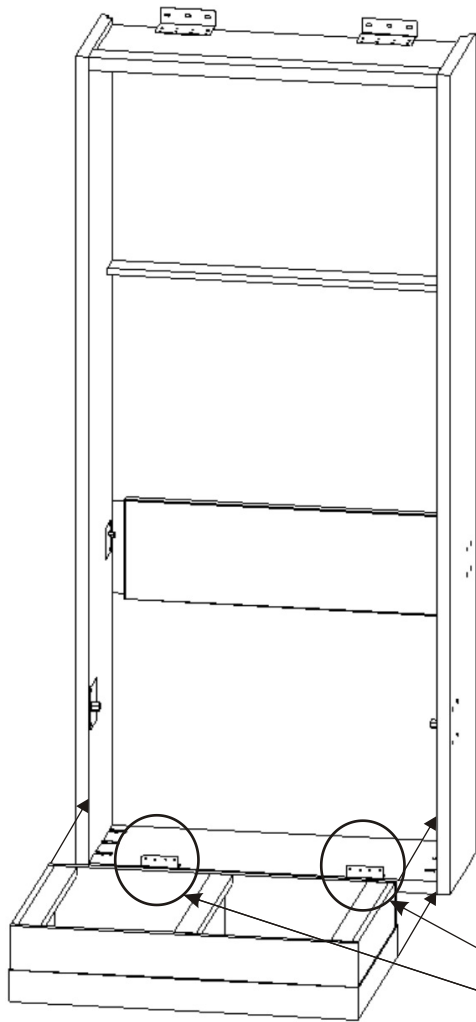

8.

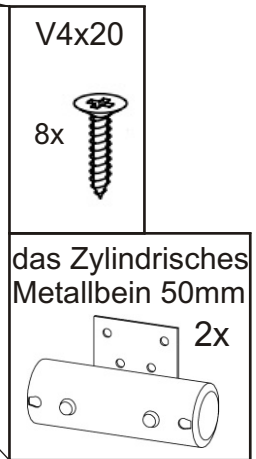
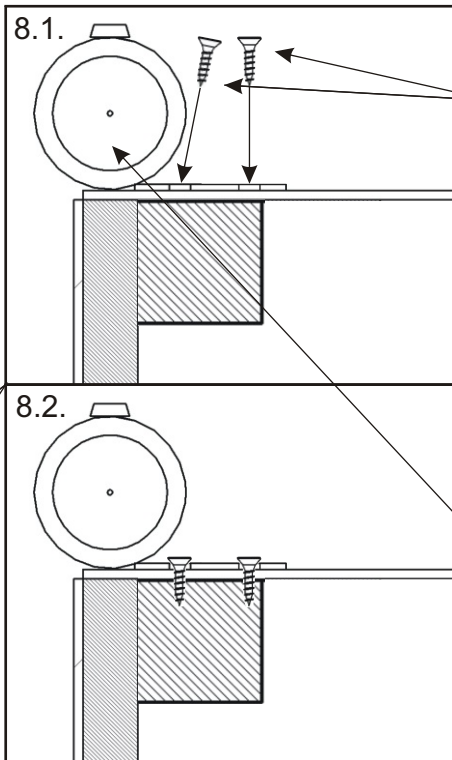
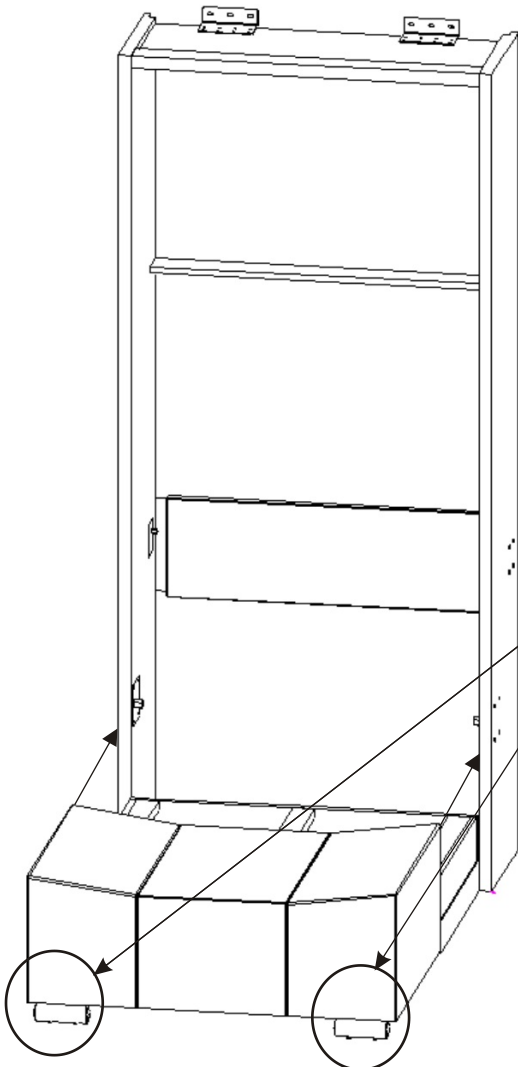



15.9.

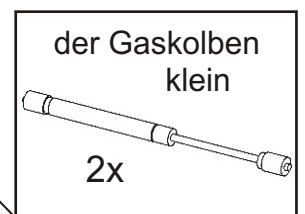
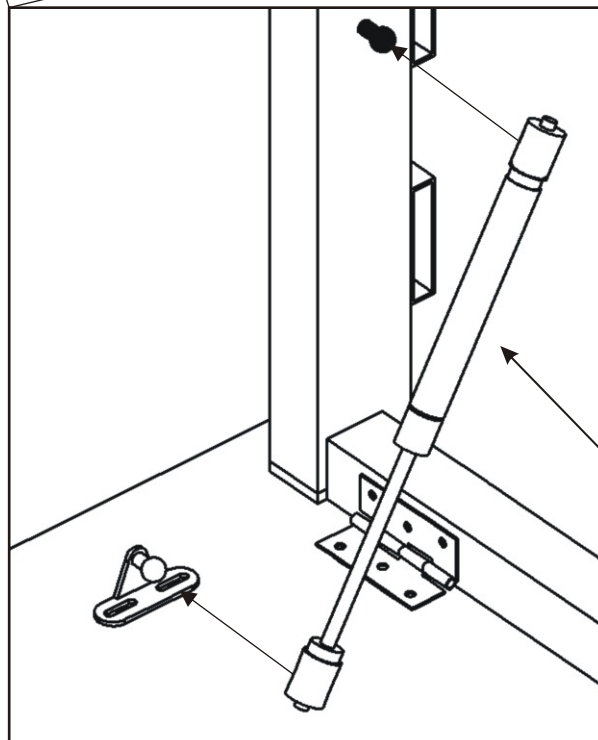
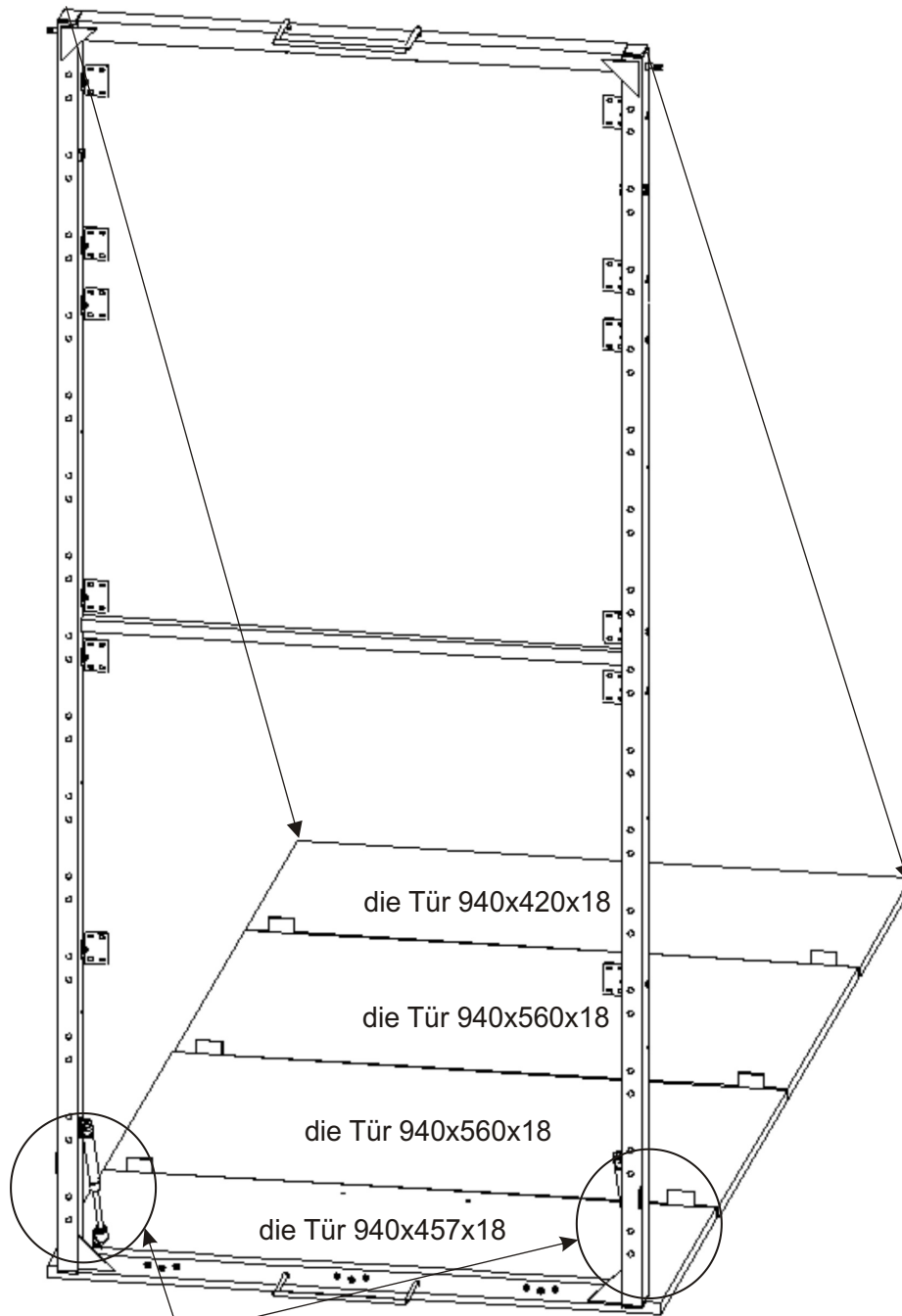

## 15.10. Andere Türen anbringen

*Richten Sie die Türkanten an der Ebene aus.*

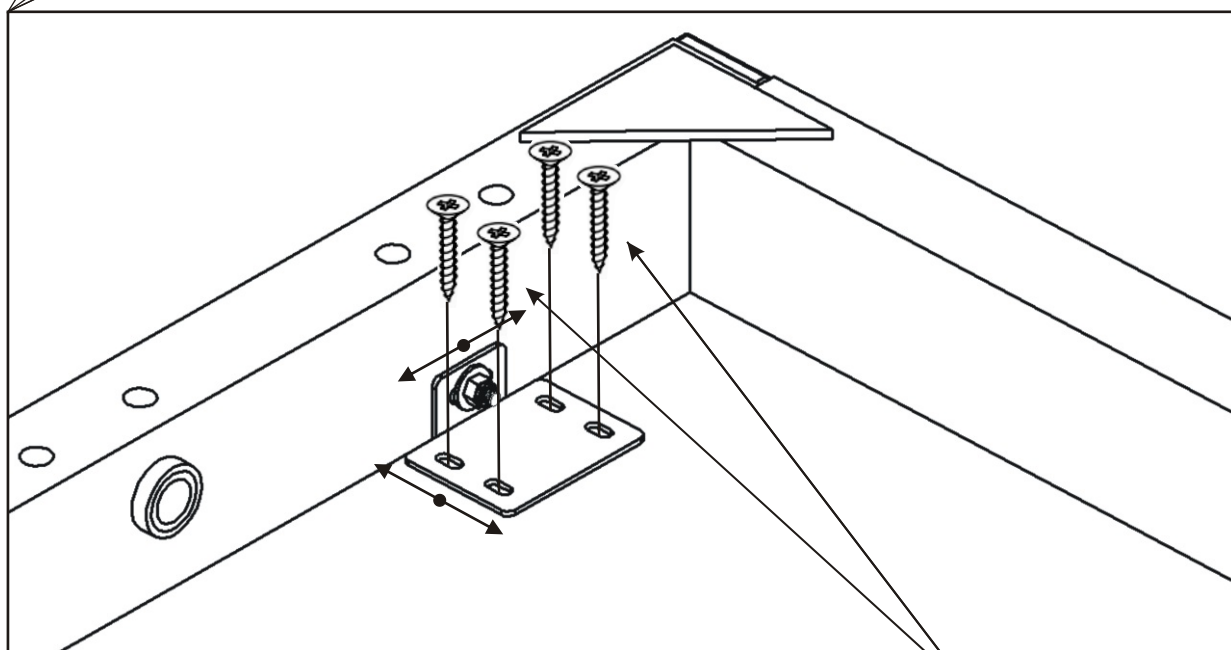
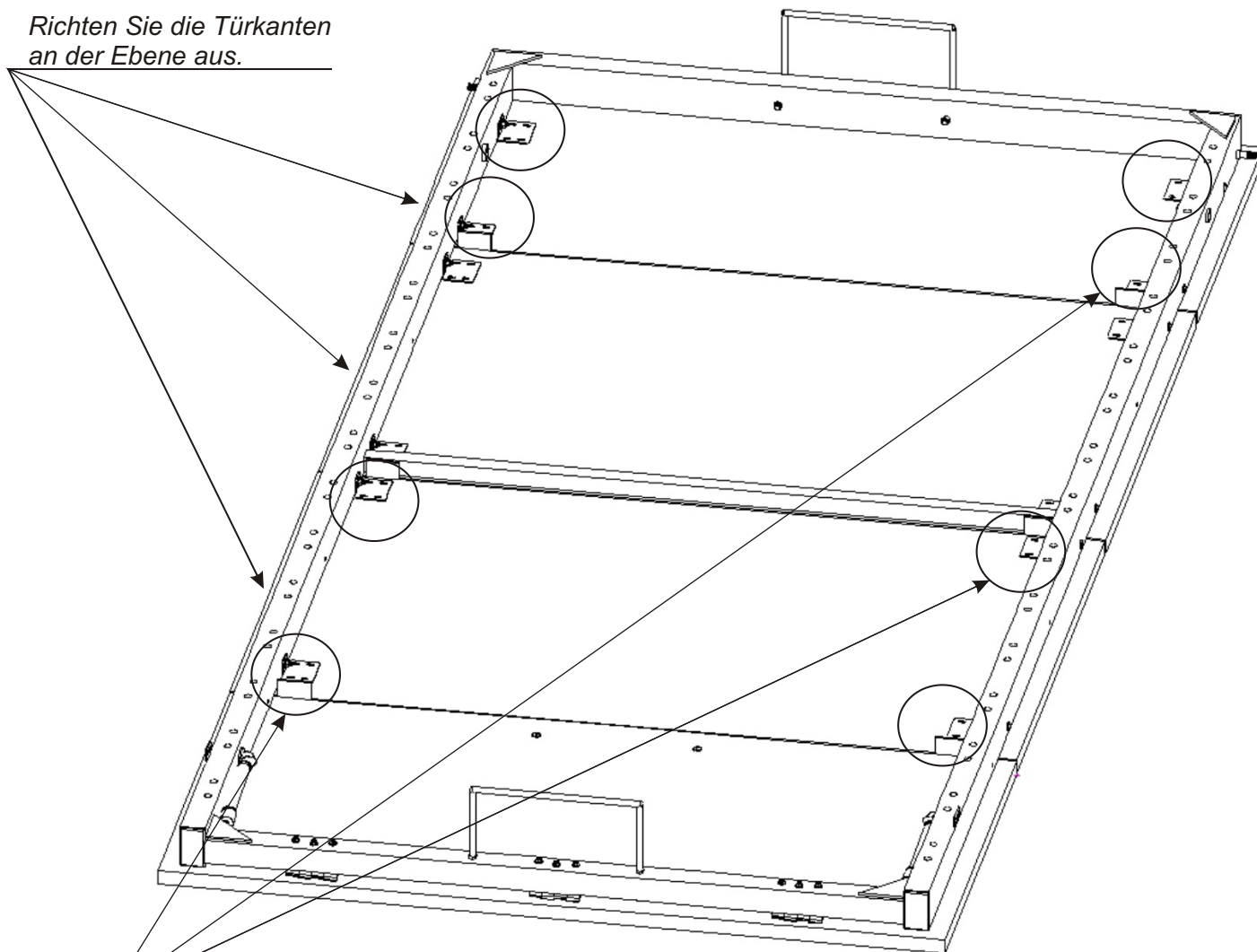

*Befestigen Sie den Bettrahmen mit den Schrauben an der Tür.  
Befestigen Sie das mittlere Türbrett nicht an.*

V4x17

32x



15.11.

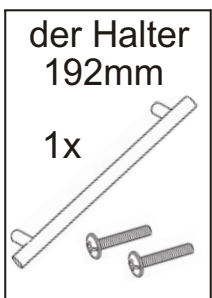
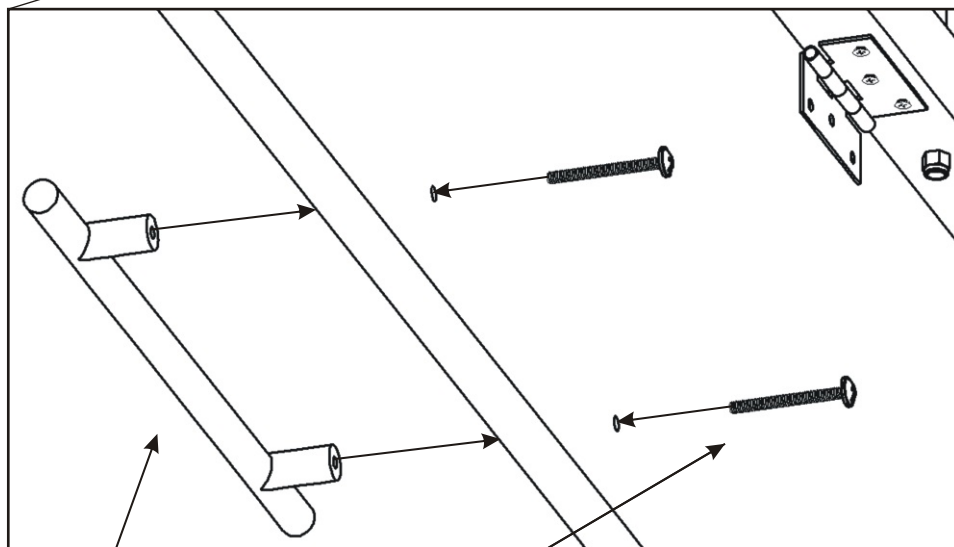
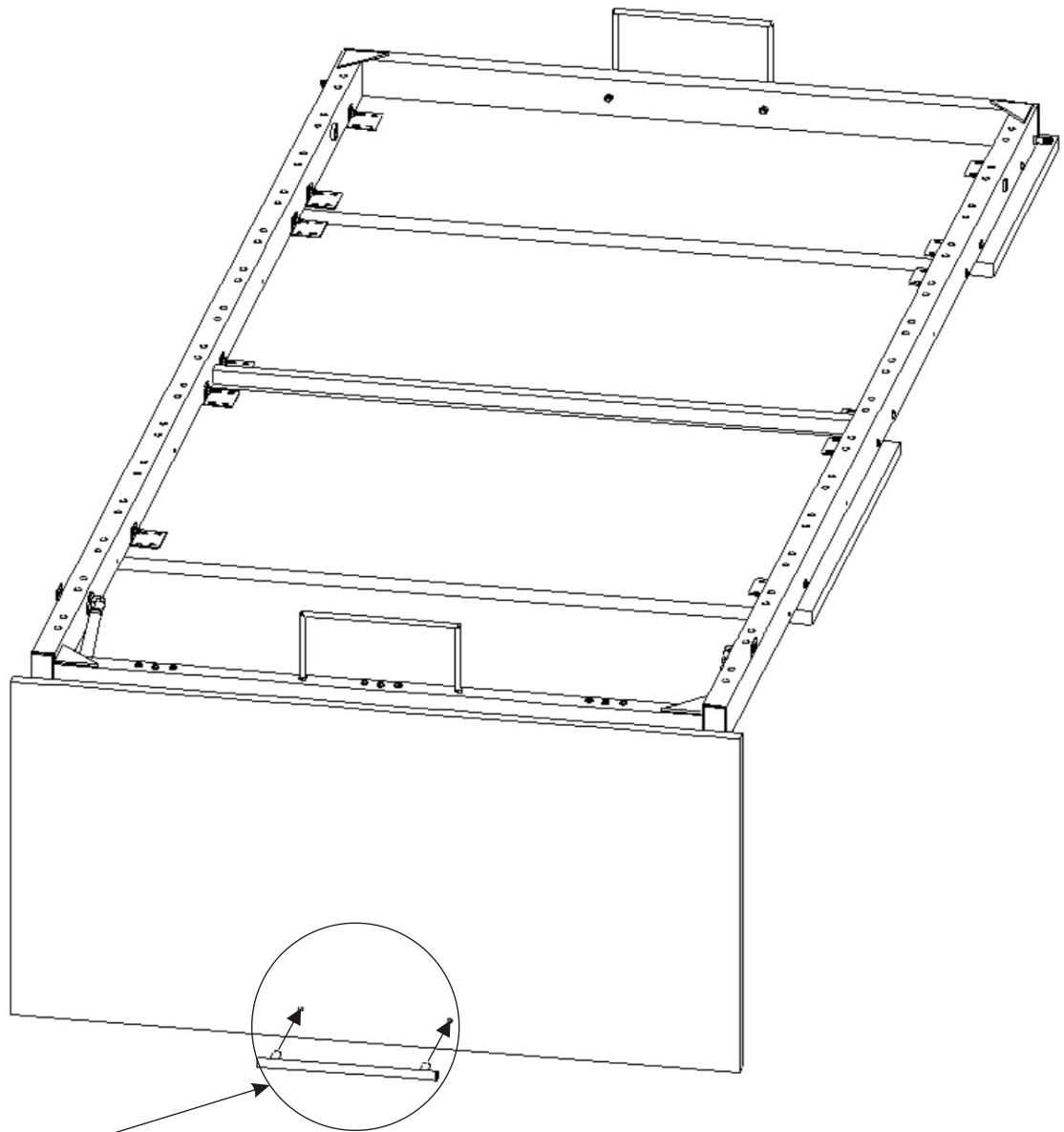

## 15.12. Anbringen eines großen Kolbens

*Befestigen Sie den großen Kolben am Rahmen und sichern Sie ihn mit einer Mutter. Ziehen Sie die Mutter nicht fest, der Kolben muss sich bewegen können.*

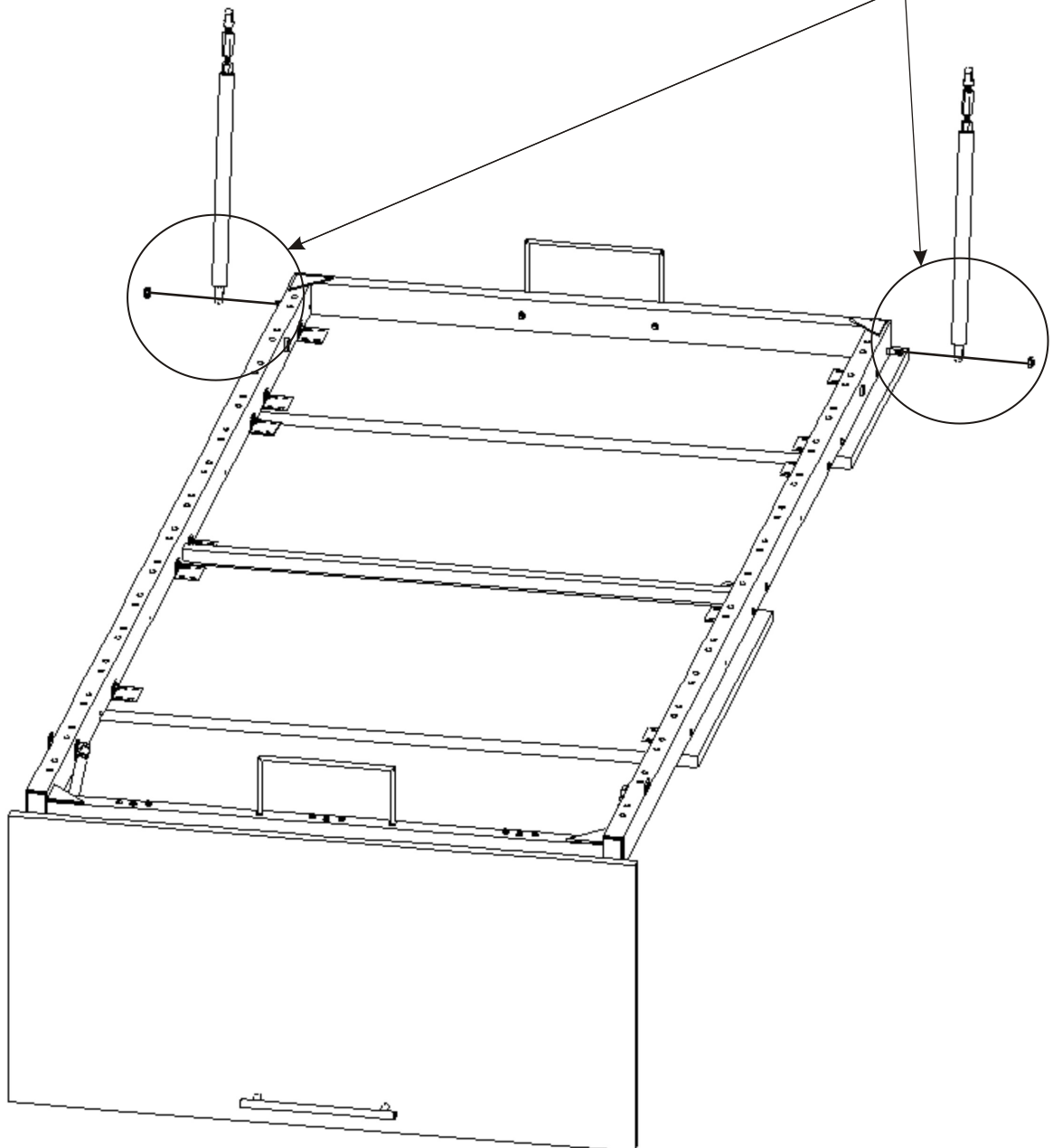
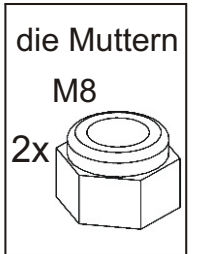
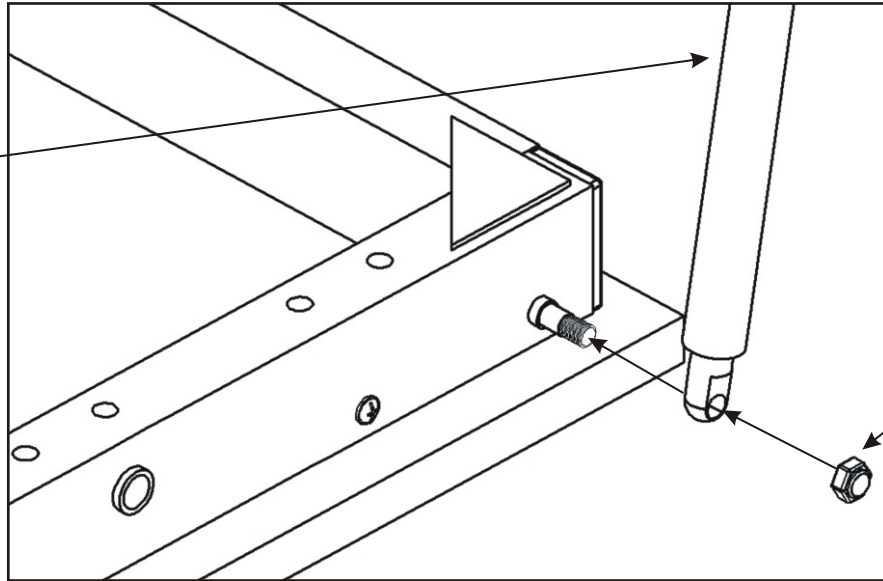
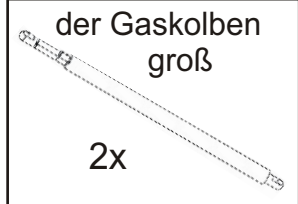

16.

1. Schieben Sie den Rahmen mit einem Kollegen in der Körper.
  2. Schrauben Sie den Bettrahmen mit einer M12x70-Schraube und einer Unterlegscheibe an die Bodenplatte des Bettkörpers an.
- Ziehen Sie nicht die Schrauben fest, der Rahmen muss sich frei drehen lassen!

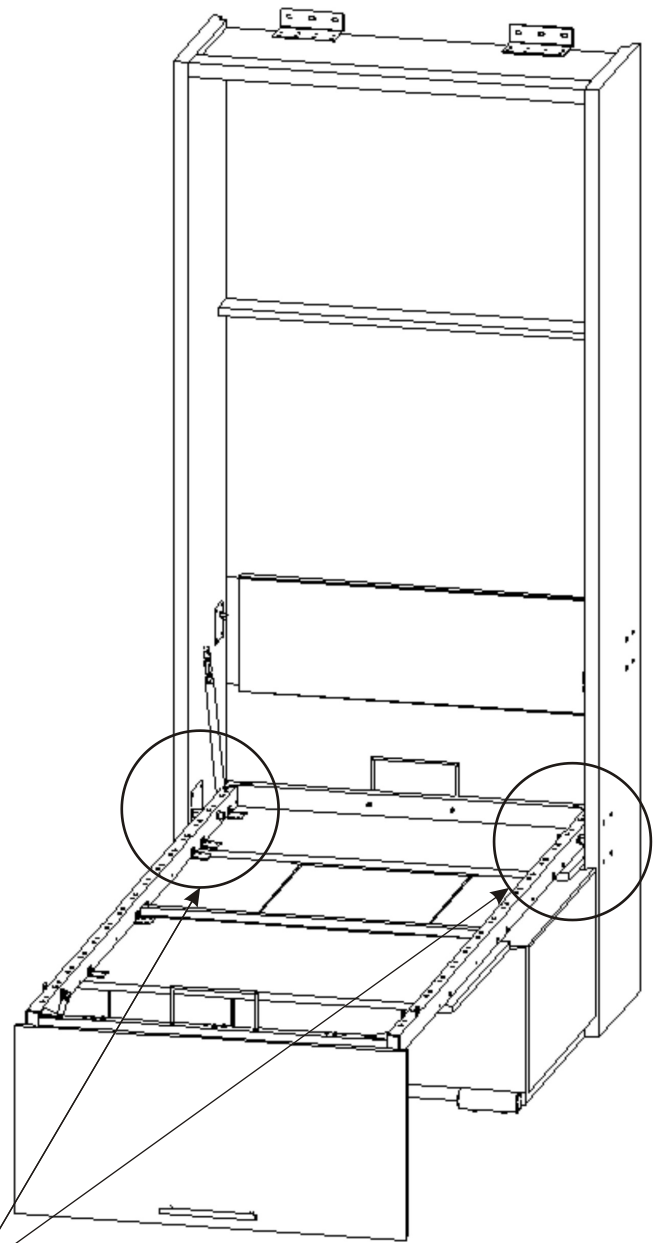

die Unterlage  
4x M13

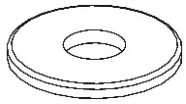

16.1.

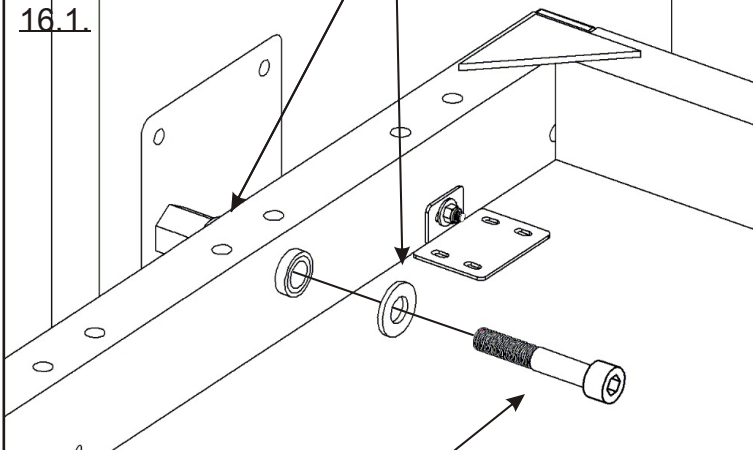

16.2.

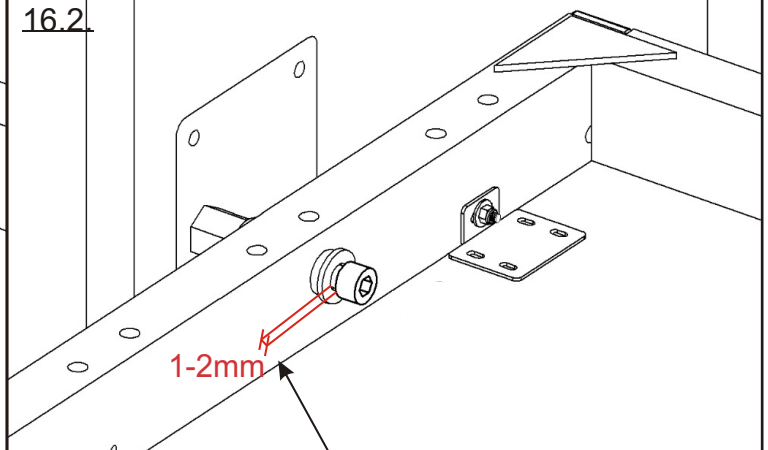

M12x70

2x



Ziehen Sie die Schraube M12x70 nicht ganz fest, sondern lassen Sie einen Spalt von ca. 1-2 mm zwischen Schraubenkopf und Unterlegscheibe. Andernfalls besteht die Gefahr einer irreparablen Beschädigung des Rahmens !!!

17.

1. Stellen Sie die Tür in eine horizontale Position und schieben Sie den gesamte bewegliche Teil nach innen.
2. Setzen Sie nun die Kolben locker in den oberen Stifte ein.

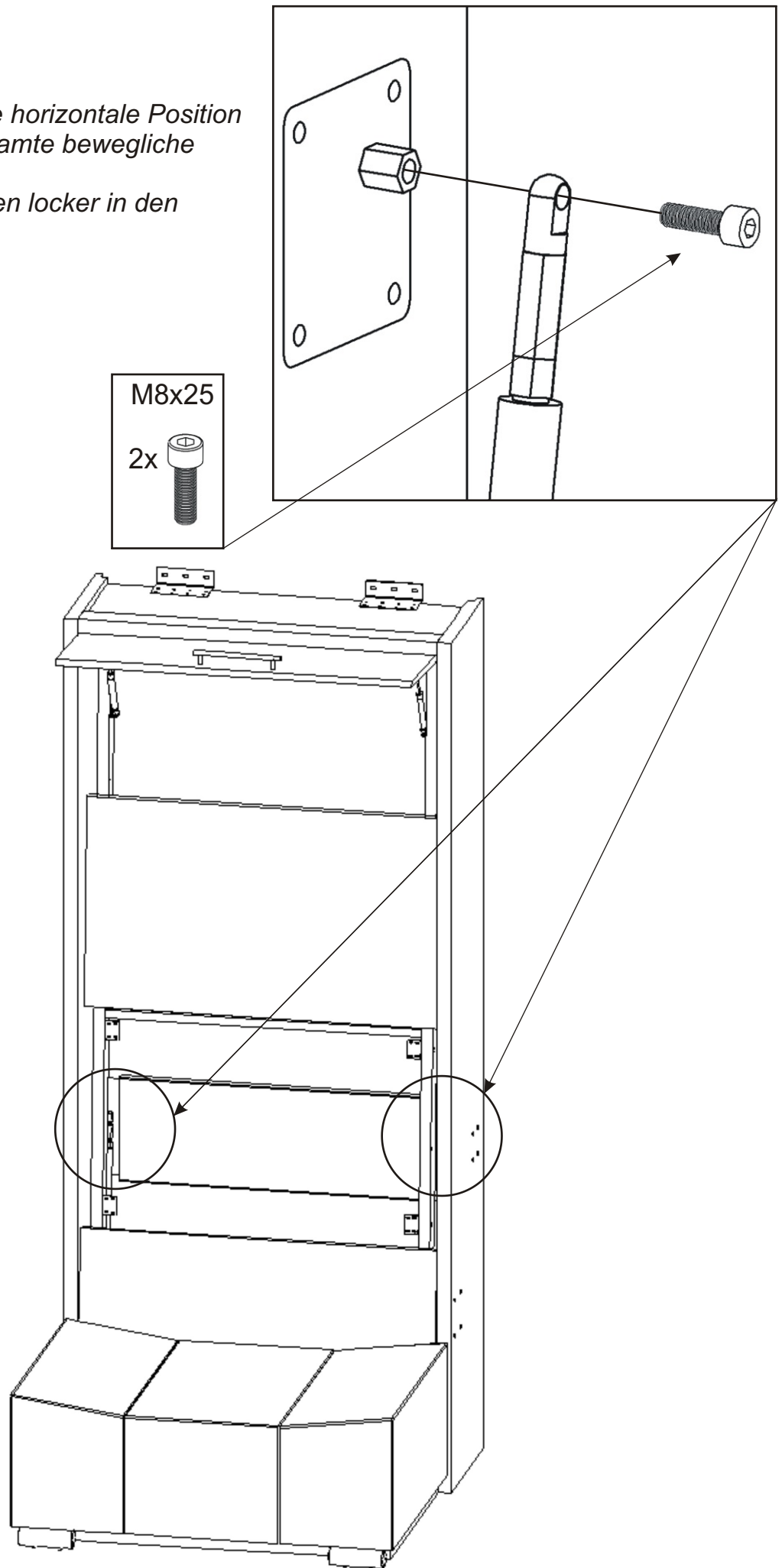

## 18. Einstellung zum Anziehen der Tür

Verwenden Sie diese Kolbeneinstellung nur, wenn sich die Tür und die Matratze nicht schließen zusammen.

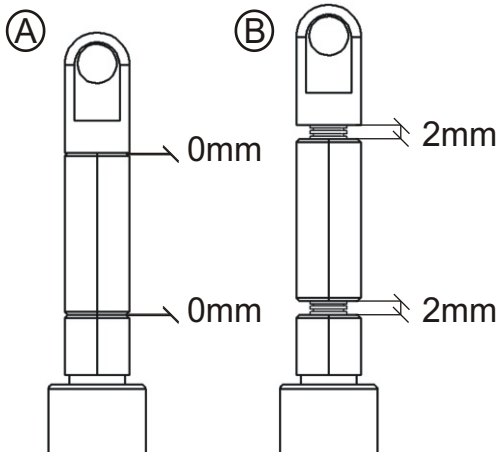
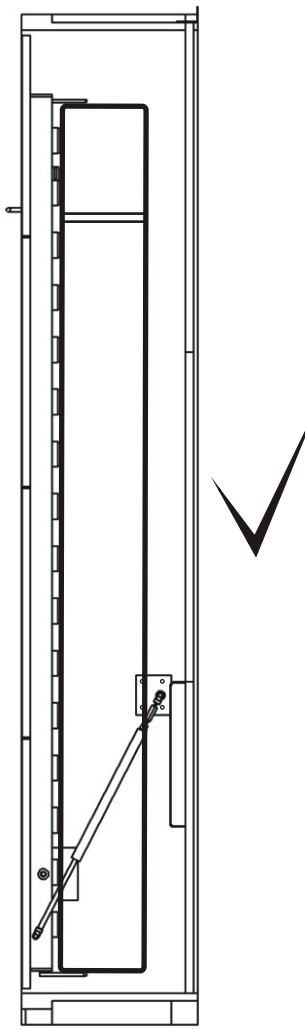
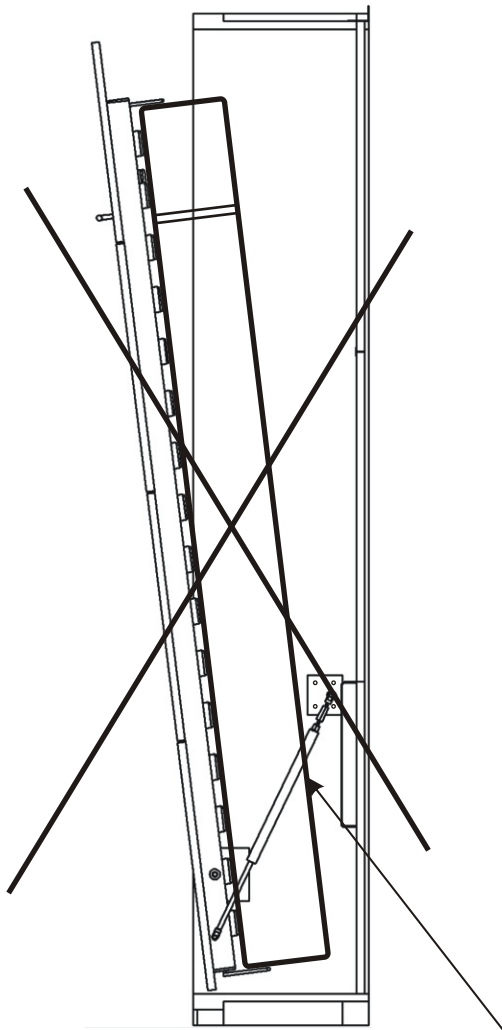

### Die Einstellung des Abstands der Kolben

Zur Montage des Klappbettes verwenden Sie die Kolben, die als in der Abbildung A eingestellt sind.

Wenn sich die Tür mit der Matratze nicht übereinstimmt, stellen Sie den Kolbenabstand ein, in dem Sie ihn leicht um ca. 1 bis 2mm öffnen. Maximal 2mm!!!

Wenn Sie einen größeren Abstand einstellen, werden die Kolben dauerhaft beschädigt. Dieser Schaden werden von der Reklamation abgedeckt.

der Kolbenabdeckung

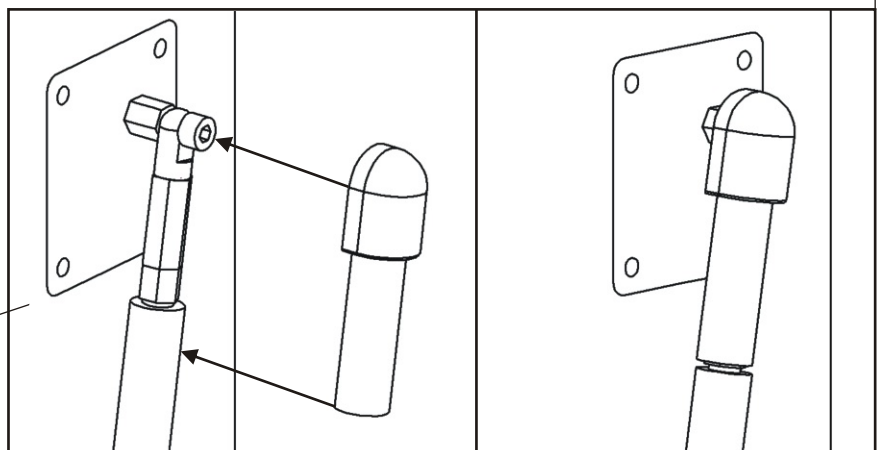
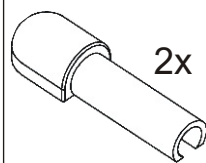

19.

Befestigen Sie die Stoppleiste 20mm von der Vorderkante.

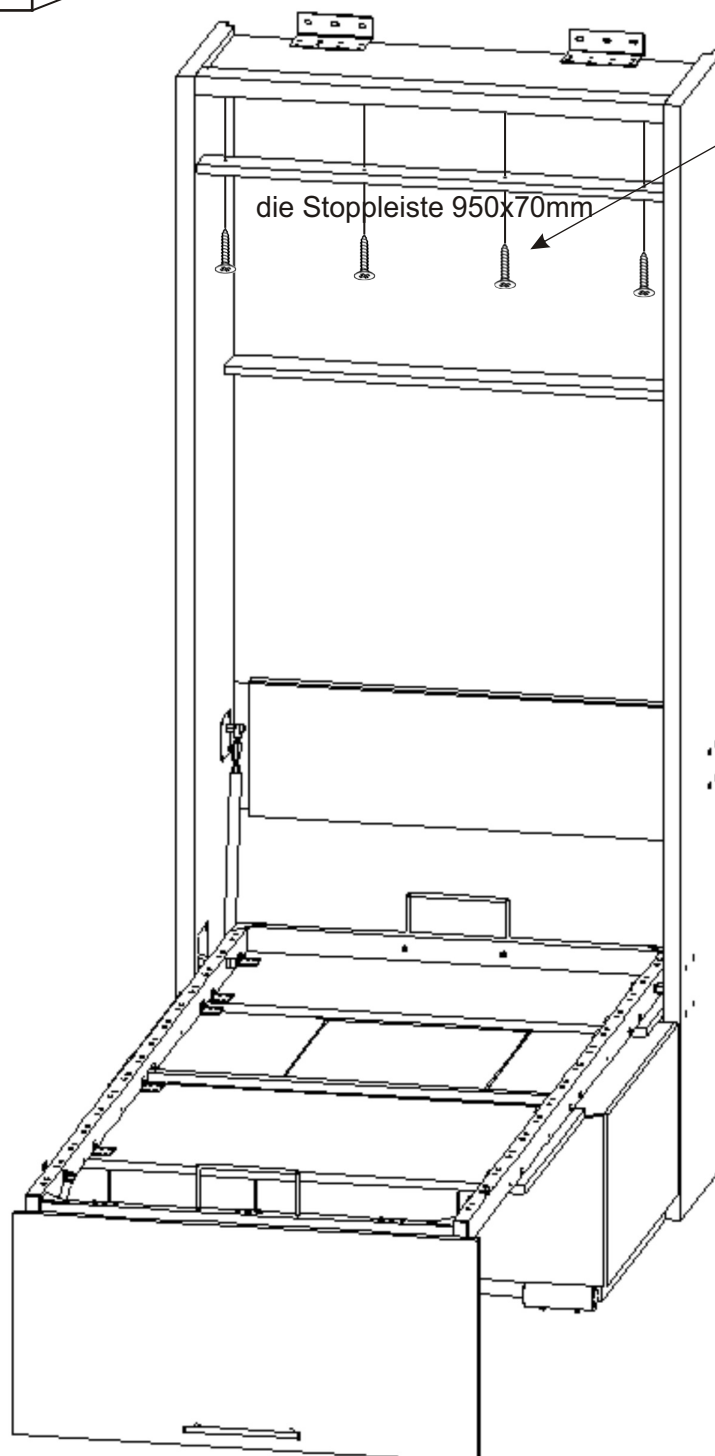
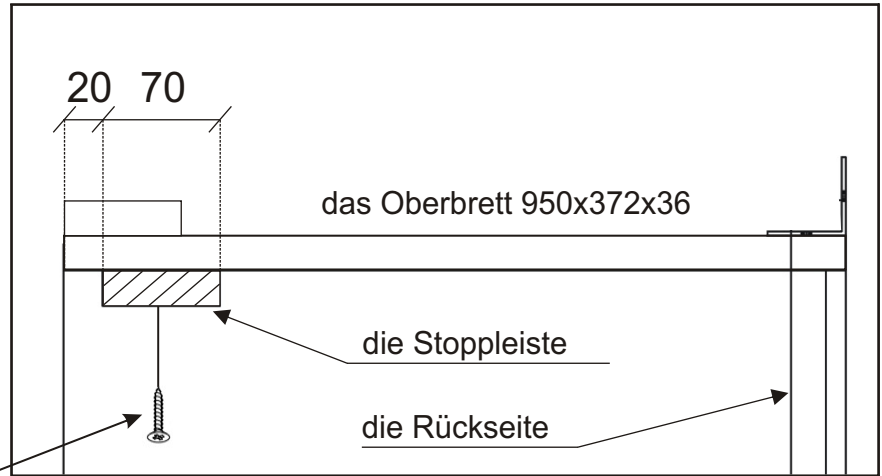
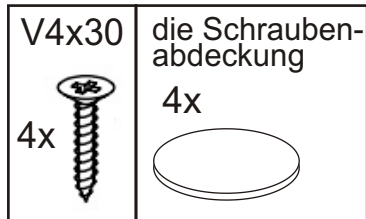



20.

der Türstopper

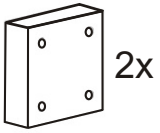

die Stoppleiste

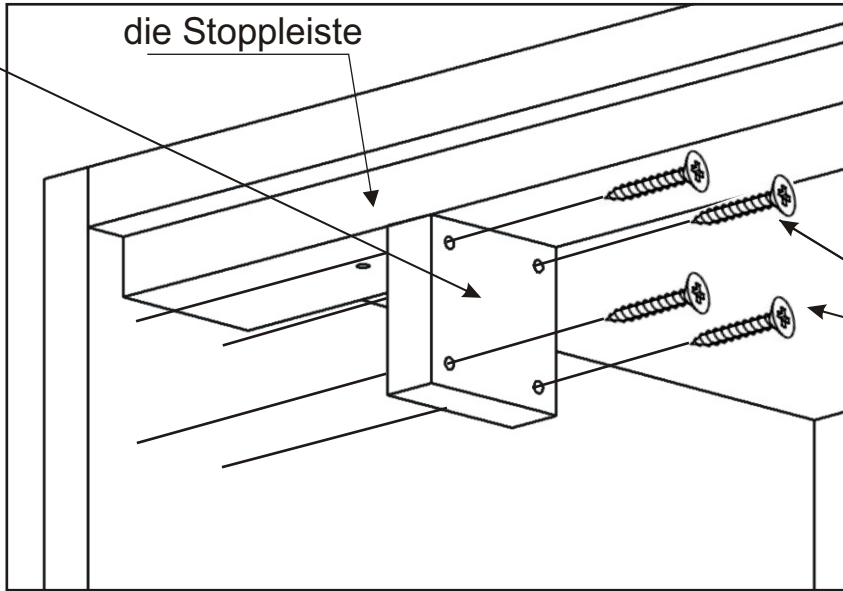

V4x35 die Schrauben-  
abdeckung



8x

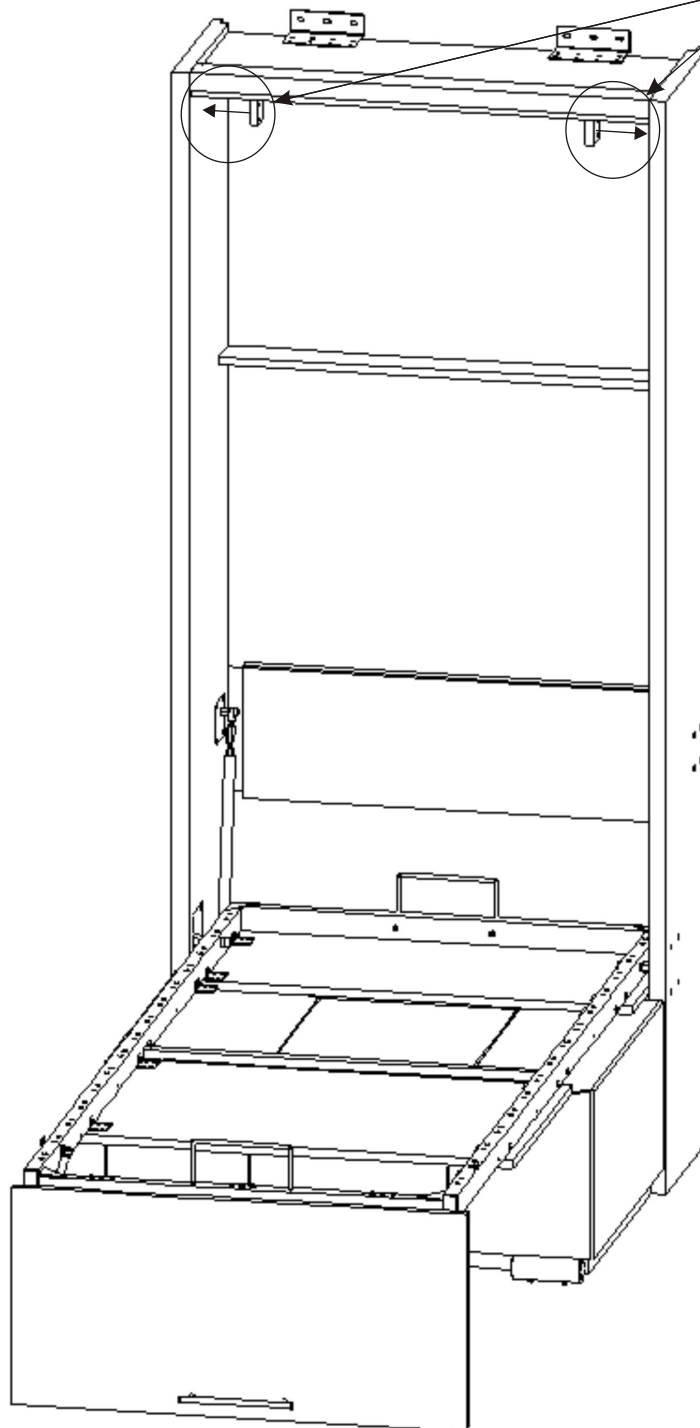

21.

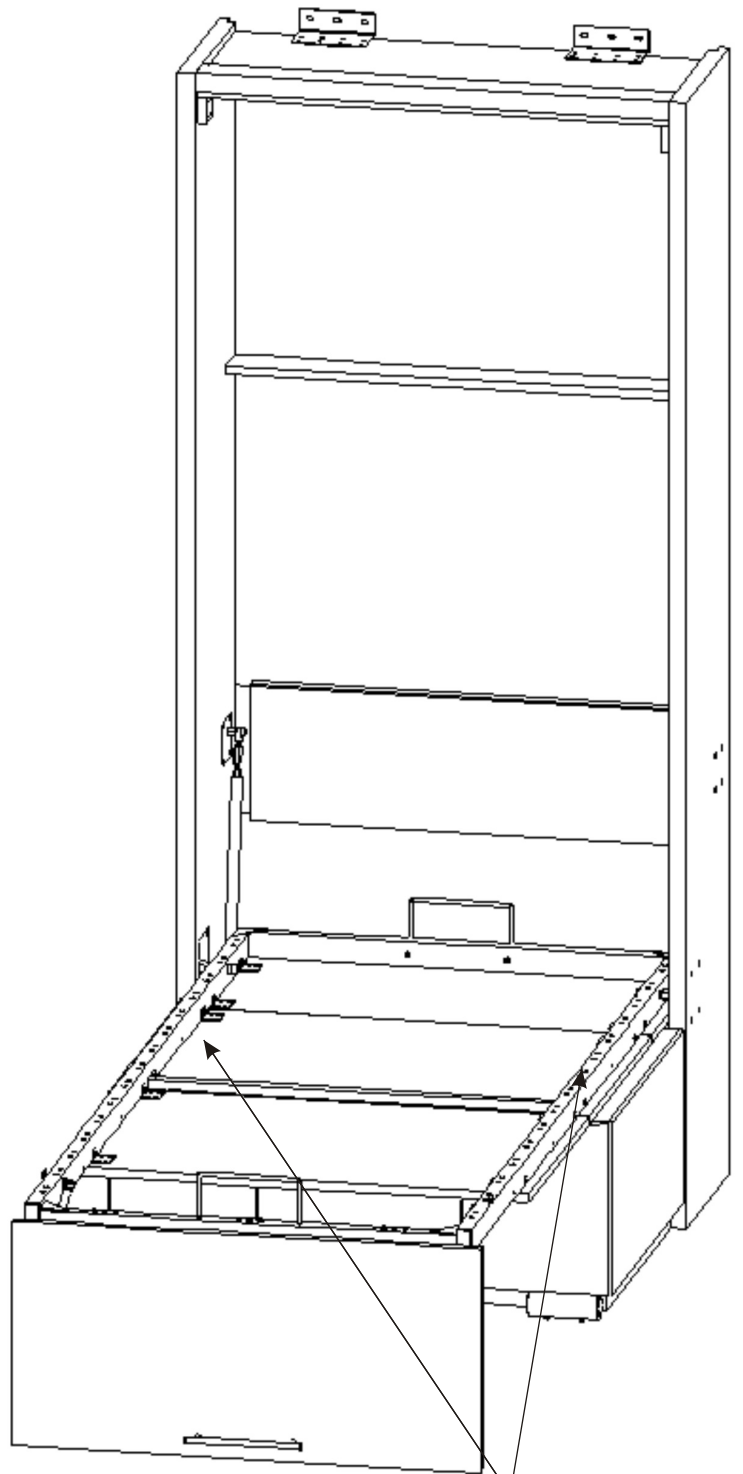

*Richten Sie die Türkanten an der Ebene aus*

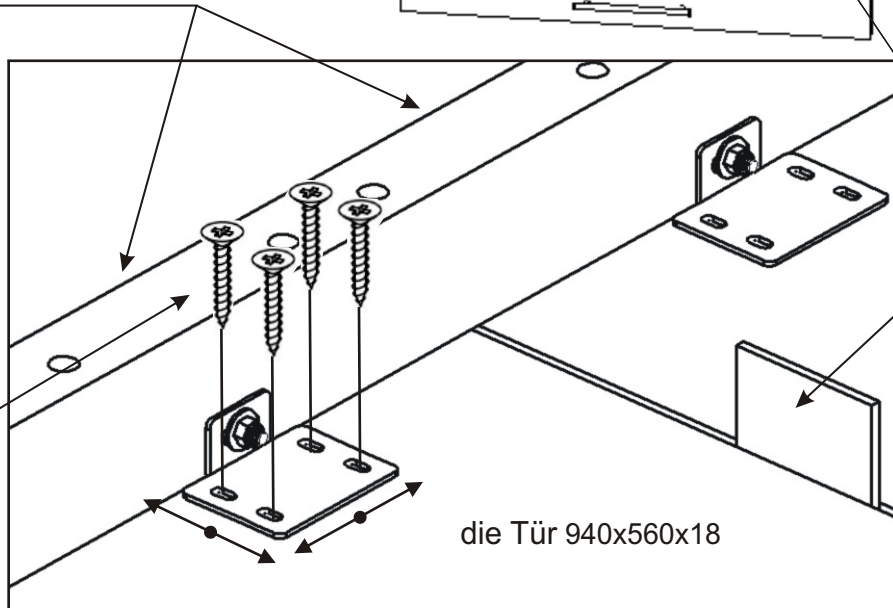

Vorbereitung zur korrekten Türmontage  
MDF 3mm  
4x

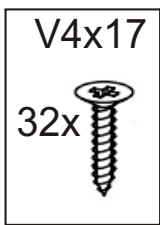

die Tür 940x560x18

## 22. Einsatz von Lamellen

1. Befestigen Sie den Plastiklamellenhalter an eines Ende der Lamelle.
2. Legen Sie das freie Ende der Lamelle auf den Rahmenhalter.

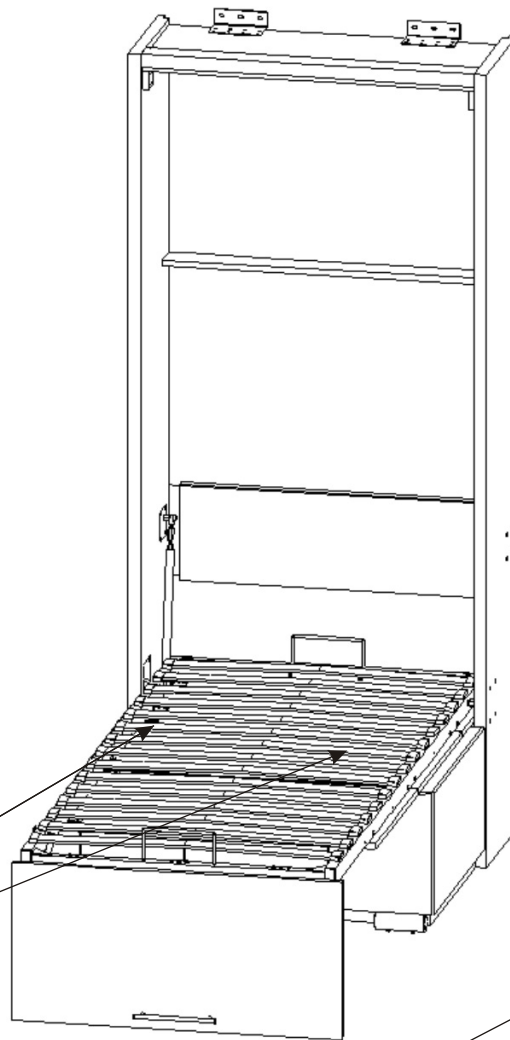

22.1.

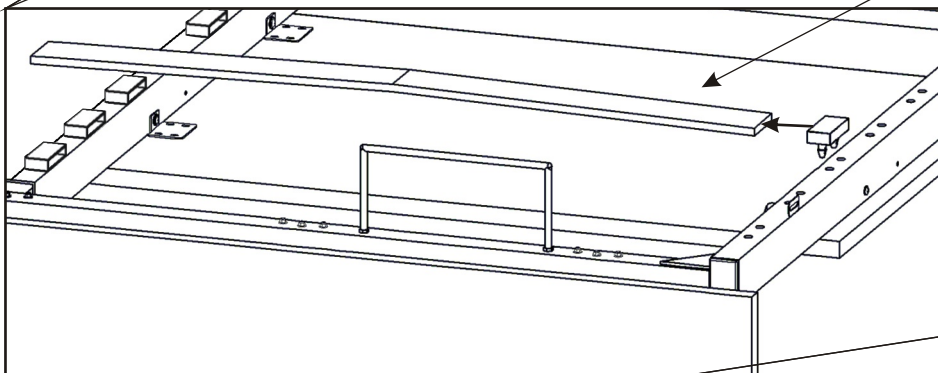

die Lamellen

15x

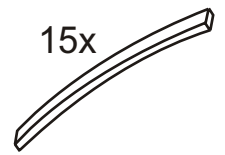

22.2.

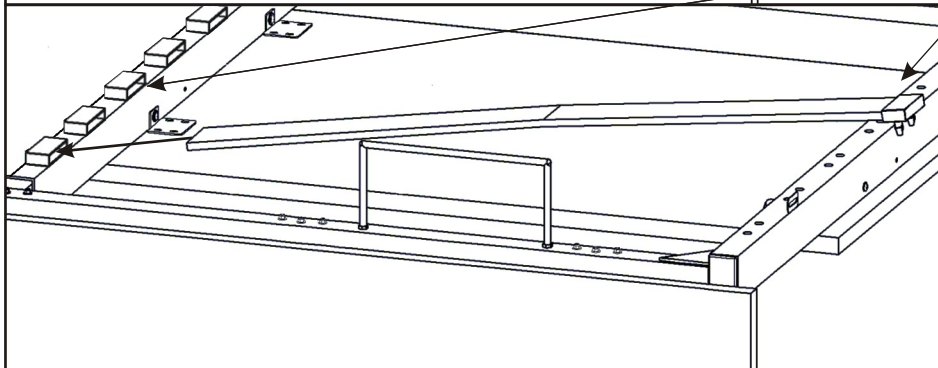

der Lamellenhalter

30x

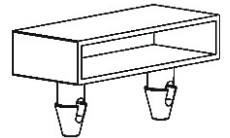

22.3.

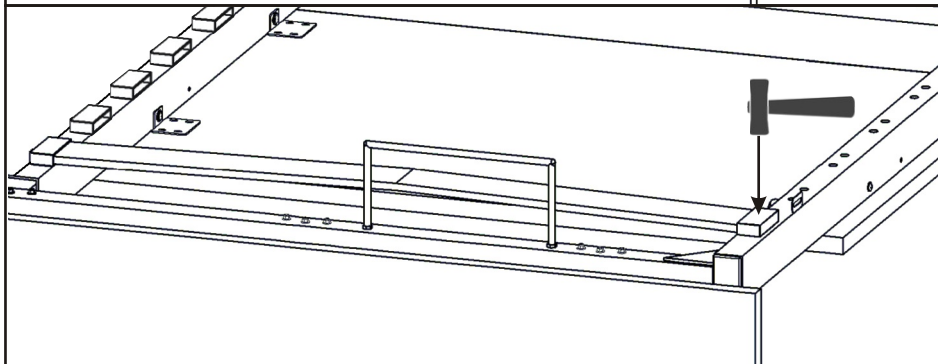

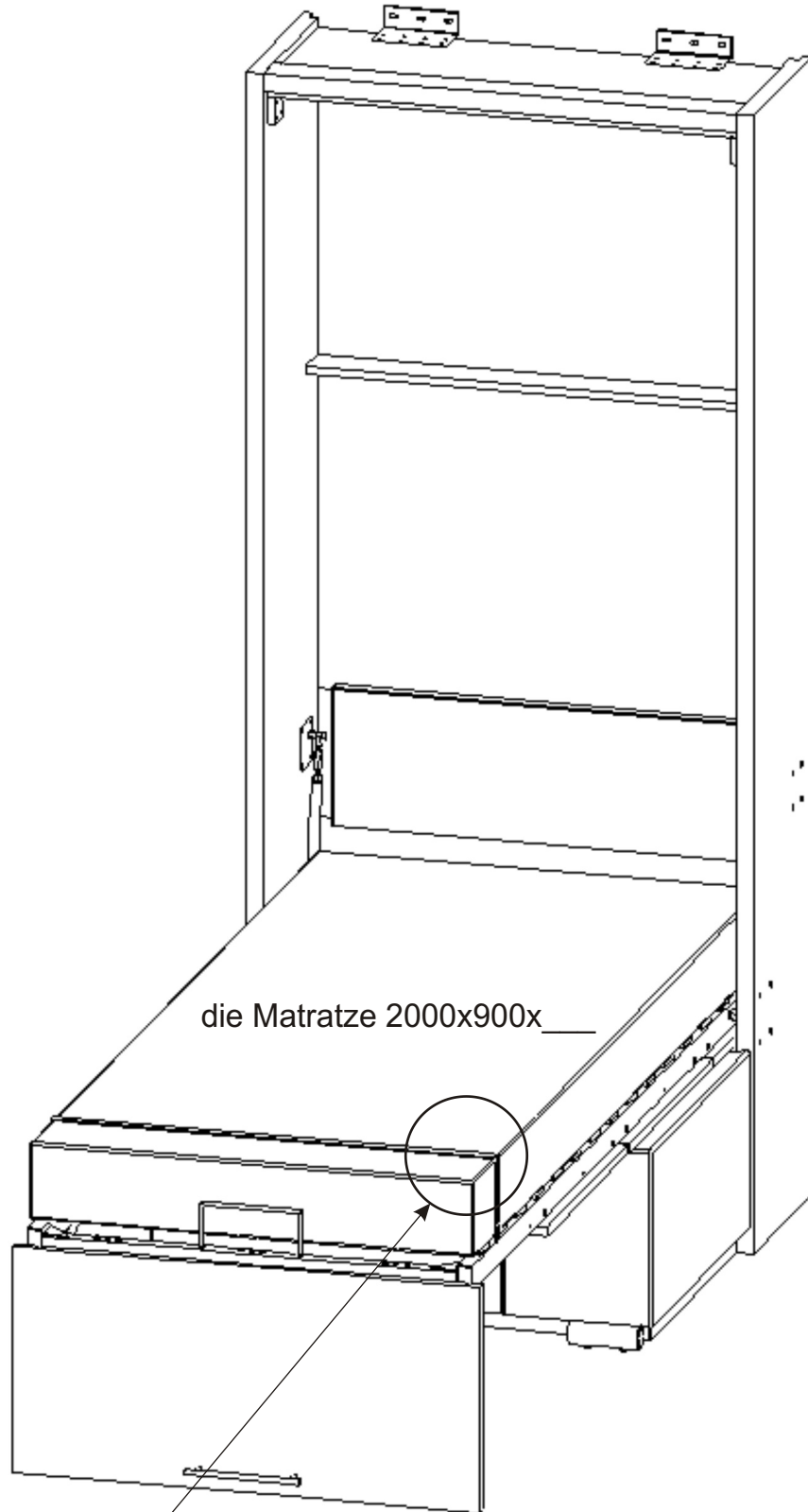

die Matratze 2000x900x

